

IE4

SERIES THREE-PHASE INDUCTION MOTOR

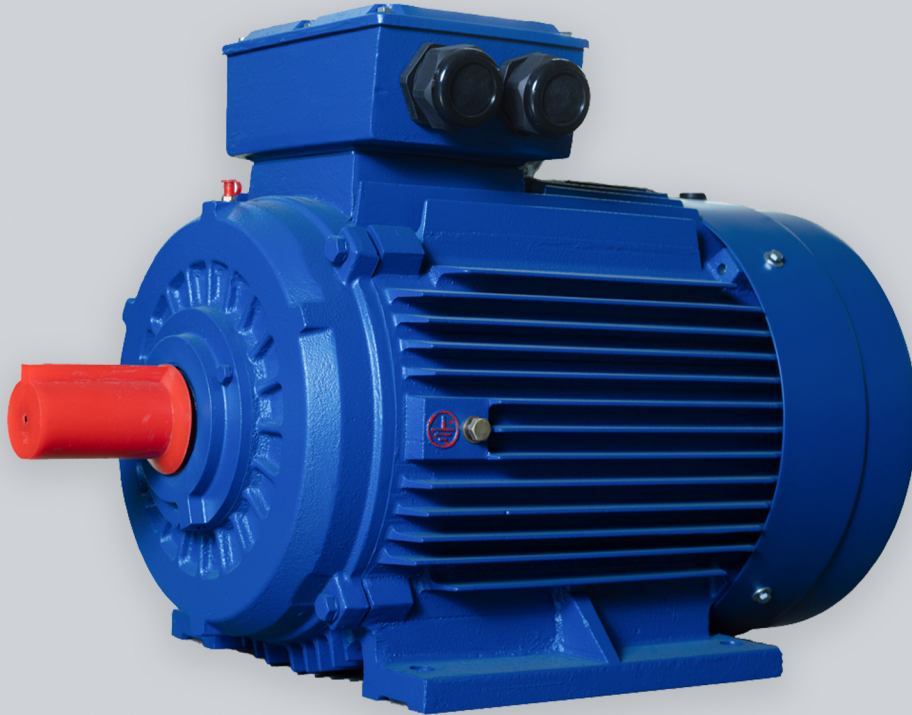

PRODUCT INTRODUCTION

SUNVIM IE4 electric motors are manufactured according to international standard IEC60034-30-1:2014. All IE4 motors are manufactured with premium grade silicon steel, low harmonics winding, low noise and low friction bearings, low wind resistance and low noise cooling fans. They are widely used to drive various general equipments, like fans, pumps, machining tools compressors, and transport machineries. The motors can also work safely and stably in industry field of petroleum, chemical-steel, mining and other places where there is with heavy load and harsh operating environment. The motors can be provided with protection grade IP55, IP56, IP65, IP66 and insulation grade F, H, temperature rise grade B. SUNVIM IE4 motors are registered in national energy label system, and have obtained china certificate for energy conservation product.

SPECIFICATION

Standard: IEC60034-30-1
Frame size: H80-355mm
Rated power: 0.718kW-315kW
Degrees or energy efficiency: IE4
Voltage and frequency: 400V/ 50Hz
Degrees of protections: IP55
Degrees of insulation/Temperature rise: F/B
Installation Method: B3\ B5\B35\V1
Ambient temperature: -15°C~+40°C
Relative humidity should be less than 90%
Altitude should be lower than 1000 m above sea level
Cooling Method: IC411 、 IC416、 IC418、 IC410

2-pole,3000r/min synchronous speed

Model	Power (kW)	Speed (r/min)					Current (A)					Speed (r/min)	Eff.			Power Factor	Rated Torque (Nm)	T _{st} /T _n (Times)	T _{max} /T _n (Times)	I _{st} /I _n (Times)	Noise dB (A)	W. T (kg)	Inertia (kg·m ²)
		220V	380V	660V	230V	400V	690V	240V	415V	720V	100%		75%	50%									
IE4-80M1-2	0.75	2910	2.84	1.64	0.95	2.8	1.6	0.9	2.6	1.5	0.9	2910	83.5	83.2	82.1	0.83	2.5	2.2	2.3	8.5	62	18	0.0011
IE4-80M2-2	1.1	2910	4.2	2.4	1.4	3.8	2.2	1.3	3.8	2.2	1.3	2910	85.2	85.0	83.7	0.83	3.6	2.2	2.3	8.5	62	19	0.0022
IE4-90S-2	1.5	2910	5.4	3.1	1.8	5	2.9	1.7	4.8	2.8	1.6	2910	86.5	86.2	85.1	0.85	4.9	2.2	2.3	9.0	67	25	0.0022
IE4-90L-2	2.2	2910	7.6	4.4	2.5	7.3	4.2	2.4	6.9	4	2.3	2910	88.0	87.7	86.6	0.86	7.2	2.2	2.3	9.0	67	29	0.0033
IE4-100L-2	3	2910	10.2	5.9	3.4	9.7	5.6	3.2	9.4	5.4	3.1	2910	89.1	88.8	87.7	0.87	9.9	2.2	2.3	9.5	74	38	0.0066
IE4-112M-2	4	2915	13.3	7.7	4.4	12.6	7.3	4.2	12.1	7	4	2915	90.0	89.8	88.5	0.88	13.1	2.2	2.3	9.5	77	47	0.0099
IE4-132S1-2	5.5	2920	18	10.4	6	17.1	9.9	5.7	16.6	9.6	5.5	2920	90.9	90.7	89.4	0.88	18.0	2.0	2.3	9.5	79	71	0.0264
IE4-132S2-2	7.5	2920	24.2	14	8.1	23	13.3	7.7	22.2	12.8	7.4	2920	91.7	91.5	90.2	0.89	24.5	2.0	2.3	9.5	79	77	0.0319
IE4-160M1-2	11	2935	35.2	20.3	11.7	33.4	19.3	11.1	32.2	18.6	10.7	2935	92.6	92.5	90.7	0.89	35.8	2.0	2.3	9.5	81	137	0.0737
IE4-160M2-2	15	2935	47.5	27.4	15.8	45.2	26.1	15.1	43.5	25.1	14.5	2935	93.3	93.2	91.4	0.89	48.8	2.0	2.3	9.5	81	150	0.0880
IE4-160L-2	18.5	2935	58.4	33.7	19.5	55.4	32	18.5	53.5	30.9	17.8	2935	93.7	93.6	91.8	0.89	60.2	2.0	2.3	9.5	81	169	0.1067
IE4-180M-2	22	2940	69.3	40	23.1	65.8	38	21.9	63.4	36.6	21.1	2940	94.0	93.9	92.1	0.89	71.5	2.0	2.3	9.5	83	219	0.1507
IE4-200L1-2	30	2950	93.9	54.2	31.3	89.2	51.5	29.7	85.9	49.6	28.6	2950	94.5	94.4	92.6	0.89	97.1	2.0	2.3	9.0	84	286	0.2497
IE4-200L2-2	37	2950	115	66.6	38.5	110	63.3	36.5	106	61	35.2	2950	94.8	94.8	93.0	0.89	120	2.0	2.3	9.0	84	306	0.2959
IE4-225M-2	45	2970	140	80.9	46.7	133	76.8	44.3	128	74	42.7	2970	95.0	94.9	93.1	0.89	145	2.0	2.3	9.0	86	359	0.3960
IE4-250M-2	55	2970	171	98.5	56.9	162	93.6	54	156	90.2	52.1	2970	95.3	95.1	93.3	0.89	177	2.0	2.3	9.0	89	475	0.8701
IE4-280S-2	75	2975	232	134	77.4	220	127	73.3	213	123	71	2975	95.6	95.5	93.7	0.89	241	1.8	2.3	8.5	91	620	1.0560
IE4-280M-2	90	2975	277	160	92.4	263	152	87.8	255	147	84.9	2975	95.8	95.7	93.9	0.89	289	1.8	2.3	8.5	91	673	1.2727
IE4-315S-2	110	2980	—	196	113	—	186	107	—	179	103	2980	96.0	95.9	94.1	0.89	353	1.8	2.3	8.5	92	975	1.8282
IE4-315M-2	132	2980	—	234	135	—	223	129	—	214	124	2980	96.2	96.1	94.3	0.89	423	1.8	2.3	8.5	92	1110	2.0614
IE4-315L1-2	160	2980	—	284	164	—	269	155	—	260	150	2980	96.3	96.2	94.4	0.89	513	1.8	2.2	8.5	92	1182	2.3606
IE4-315L2-2	185	2980	—	328	189	—	312	180	—	300	173	2980	96.3	96.2	94.4	0.89	593	1.8	2.2	8.5	92	1215	2.4926
IE4-315L3-2	200	2980	—	354	204	—	336	194	—	324	187	2980	96.5	96.4	94.6	0.89	641	1.8	2.2	8.5	92	1260	2.6928
IE4-355M1-2	220	2980	—	389	225	—	370	214	—	356	206	2980	96.5	96.5	94.6	0.89	705	1.6	2.2	8.5	100	1810	2.9623
IE4-355M2-2	250	2980	—	433	250	—	411	237	—	396	229	2980	96.5	96.5	94.6	0.91	801	1.6	2.2	8.5	100	1860	4.4374
IE4-355L1-2	280	2980	—	484	279	—	460	266	—	444	256	2980	96.5	96.5	94.6	0.91	897	1.6	2.2	8.5	100	1952	4.5045
IE4-355L2-2	315	2980	—	545	315	—	518	299	—	499	288	2980	96.5	96.5	94.6	0.91	1009	1.6	2.2	8.5	100	2052	5.1095

4-pole, 1500r/min synchronous speed

Model	Power	Current (A)					Current (A)			Speed (r/min)	Eff.			Power Factor	Rated Torque	T _{st} /T _n (Times)	T _{max} /T _n (Times)	I _{av} /I _n (Times)	Noise dB (A)	W. T (kg)	Inertia (kg. m ²)	
		220V	380V	660V	230V	400V	690V	240V	415V		720V	100%	75%									50%
IE4-80M2-4	0.75	3.1	1.8	1	2.9	1.7	1	2.8	1.6	0.9	1430	85.7	85.4	83.1	0.74	5.0	2.3	2.3	8.5	56	20	0.0033
IE4-90S-4	1.1	4.5	2.6	1.5	4.2	2.4	1.4	4	2.3	1.3	1435	87.2	86.9	85.7	0.75	7.3	2.3	2.3	8.5	59	25	0.0044
IE4-90L-4	1.5	5.9	3.4	2	5.5	3.2	1.8	5.4	3.1	1.8	1435	88.2	87.9	86.8	0.76	10.0	2.3	2.3	9.0	59	30	0.0055
IE4-100L1-4	2.2	8.1	4.7	2.7	7.8	4.5	2.6	7.4	4.3	2.5	1450	89.5	89.3	88.2	0.79	14.5	2.3	2.3	9.0	64	41	0.0132
IE4-100L2-4	3	10.9	6.3	3.6	10.4	6	3.5	10	5.8	3.3	1450	90.4	90.2	88.9	0.80	19.8	2.3	2.3	9.5	64	46	0.0176
IE4-112M-4	4	14.4	8.3	4.8	13.7	7.9	4.6	13.2	7.6	4.4	1455	91.1	90.8	89.6	0.80	26.3	2.3	2.3	9.5	65	55	0.0242
IE4-132S-4	5.5	19.7	11.4	6.6	18.7	10.8	6.2	18	10.4	6	1460	91.9	91.7	90.3	0.80	36.0	2.0	2.3	9.5	71	78	0.0660
IE4-132M-4	7.5	26.3	15.2	8.8	24.9	14.4	8.3	24.1	13.9	8	1460	92.6	92.4	90.9	0.81	49.1	2.0	2.3	9.5	71	92	0.0781
IE4-160M-4	11	37.4	21.6	12.5	35.5	20.5	11.8	34.3	19.8	11.4	1470	93.3	93.2	91.4	0.83	71.5	2.0	2.3	9.5	73	146	0.1507
IE4-160L-4	15	50.1	28.9	16.7	47.5	27.4	15.8	45.9	26.5	15.3	1470	93.9	93.8	92.0	0.84	97.5	2.0	2.3	9.5	73	170	0.1881
IE4-180M-4	18.5	60.8	35.1	20.3	57.7	33.3	19.2	55.6	32.1	18.5	1475	94.2	94.1	92.3	0.85	120	2.0	2.3	9.5	76	197	0.2618
IE4-180L-4	22	72.1	41.6	24	68.4	39.5	22.8	66	38.1	22	1475	94.5	94.4	92.6	0.85	142	2.0	2.3	9.5	76	227	0.2849
IE4-200L-4	30	97.9	56.5	32.6	93	53.7	31	89.5	51.7	29.8	1475	94.9	94.8	93.0	0.85	194	2.0	2.3	9.0	76	297	0.5049
IE4-225S-4	37	120	69.5	40.1	114	66	38.1	110	63.6	36.7	1480	95.2	95.1	93.3	0.85	239	2.0	2.3	9.0	78	361	0.7216
IE4-225M-4	45	146	84.3	48.7	139	80.1	46.2	134	77.2	44.6	1480	95.4	95.3	93.5	0.85	290	2.0	2.3	9.0	78	391	0.8338
IE4-250M-4	55	177	102	58.9	167	96.5	55.7	161	93	53.7	1485	95.7	95.7	93.9	0.86	354	2.0	2.3	9.0	79	482	1.1858
IE4-280S-4	75	236	136	78.5	225	130	75.1	217	125	72.2	1485	96.0	96.0	94.2	0.87	482	2.0	2.3	8.5	80	656	1.9800
IE4-280M-4	90	281	162	93.5	267	154	88.9	256	148	85.5	1485	96.1	96.0	94.3	0.88	579	2.0	2.3	8.5	80	693	2.3430
IE4-315S-4	110	338	195	113	320	185	107	310	179	103	1490	96.3	96.3	94.4	0.89	705	1.8	2.2	8.5	88	983	3.7565
IE4-315M-4	132	405	234	135	385	222	128	371	214	124	1490	96.4	96.4	94.5	0.89	846	1.8	2.2	8.5	88	1148	4.1877
IE4-315L1-4	160	485	280	162	461	266	154	443	256	148	1490	96.6	96.6	94.8	0.90	1026	1.8	2.2	8.5	88	1234	3.7653
IE4-315L2-4	185	559	323	186	532	307	177	513	296	171	1490	96.6	96.6	94.8	0.90	1186	1.8	2.2	8.5	88	1300	4.9269
IE4-315L3-4	200	604	349	202	575	332	192	554	320	185	1490	96.7	96.7	94.8	0.90	1282	1.8	2.2	8.5	88	1354	5.7882
IE4-355M1-4	220	—	384	222	—	365	211	—	352	203	1490	96.7	96.7	94.8	0.90	1410	1.8	2.2	8.5	95	1596	5.9939
IE4-355M2-4	250	—	436	252	—	415	240	—	400	231	1490	96.7	96.7	94.8	0.90	1602	1.8	2.2	8.5	95	1758	6.8112
IE4-355L1-4	280	—	489	282	—	464	268	—	448	259	1490	96.7	96.7	94.8	0.90	1795	1.8	2.2	8.5	95	1925	7.4052
IE4-355L2-4	315	—	550	318	—	522	301	—	504	291	1490	96.7	96.7	94.8	0.90	2019	1.8	2.2	8.5	95	2140	8.0003

8-pole,750r/min synchronous speed

Model	Power	Current (A)					Current (A)			Speed (r/min)	Eff.			Power Factor	Rated Torque	T _{st} /T _n (Times)	T _{max} /T _n (Times)	I _{st} /I _n (Times)	Noise dB (A)	W. T (kg)	Inertia (kg.m ²)	
		220V	380V	660V	230V	400V	690V	240V	415V		720V	100%	75%									50%
IE4-100L1-8	0.75	3.8	2.2	1.3	3.6	2.1	1.2	1.2	2	1.2	690	78.4	78.1	76.6	0.66	10.4	2.0	2.0	7.0	59	33	0.0077
IE4-100L2-8	1.1	5.4	3.1	1.8	5	2.9	1.7	1.6	2.8	1.6	690	80.8	80.5	79.0	0.67	15.2	2.0	2.0	7.0	59	38	0.0115
IE4-112M-8	1.5	6.9	4	2.3	6.6	3.8	2.2	2.1	3.7	2.1	690	82.6	82.3	80.8	0.69	20.8	2.0	2.0	7.0	61	48	0.0187
IE4-132S-8	2.2	9.9	5.7	3.3	9.4	5.4	3.1	3	5.2	3	710	84.5	84.3	82.8	0.70	29.6	1.8	2.0	7.5	64	68	0.0408
IE4-132M-8	3	13.2	7.6	4.4	12.5	7.2	4.2	4	6.9	4	710	85.9	85.7	84.2	0.70	40.4	1.8	2.0	7.8	64	79	0.0553
IE4-160M1-8	4	17	9.8	5.7	16.1	9.3	5.4	5.2	9	5.2	720	87.1	86.9	85.4	0.71	53.1	1.8	2.0	7.9	68	117	0.0842
IE4-160M2-8	5.5	22.7	13.1	7.6	21.7	12.5	7.2	6.9	12	6.9	720	88.3	88.1	86.6	0.72	73.0	1.8	2.0	8.1	68	130	0.1158
IE4-160L-8	7.5	29.8	17.2	9.9	28.4	16.4	9.5	9.1	15.8	9.1	720	89.3	89.1	87.6	0.74	99.5	1.8	2.0	7.8	68	152	0.1579
IE4-180L-8	11	43.3	25	14.4	41	23.7	13.7	13.2	22.9	13.2	730	90.4	90.2	88.7	0.74	144	1.8	2.0	7.9	70	197	0.2742
IE4-200L-8	15	57.7	33.3	19.2	54.9	31.7	18.3	17.6	30.5	17.6	730	91.2	91.0	89.5	0.75	196	1.8	2.0	8.0	73	250	0.4206
IE4-225S-8	18.5	70.8	40.9	23.6	67.2	38.8	22.4	21.6	37.4	21.6	730	91.7	91.5	90.0	0.75	242	1.8	2.0	8.1	73	298	0.6410
IE4-225M-8	22	82.8	47.8	27.6	78.6	45.4	26.2	25.2	43.7	25.2	740	92.1	91.9	90.4	0.76	284	1.8	2.0	8.3	73	320	0.7327
IE4-250M-8	30	111	63.9	36.9	105	60.7	35	33.8	58.5	33.8	740	92.7	92.5	91.0	0.77	387	1.8	2.0	7.9	75	429	1.1901
IE4-280S-8	37	134	77.4	44.7	127	73.5	42.4	40.9	70.9	40.9	740	93.1	92.9	91.4	0.78	478	1.8	2.0	7.9	76	557	2.0684
IE4-280M-8	45	163	93.9	54.2	154	89.2	51.5	49.6	85.9	49.6	740	93.4	93.2	91.7	0.78	581	1.8	2.0	7.9	76	616	2.4596
IE4-315S-8	55	192	111	64.1	184	106	61.2	58.9	102	58.9	740	93.7	93.6	92.4	0.80	710	1.6	2.0	8.2	82	796	4.6366
IE4-315M-8	75	262	151	87.2	249	144	83.1	79.7	138	79.7	740	94.2	94.1	92.9	0.80	968	1.6	2.0	7.6	82	978	5.9118
IE4-315L1-8	90	310	179	103	294	170	98.2	94.7	164	94.7	740	94.4	94.3	93.1	0.81	1161	1.6	2.0	7.7	82	1118	7.8824
IE4-315L2-8	110	378	218	126	359	207	120	115	200	115	740	94.7	94.6	93.4	0.81	1420	1.6	2.0	7.7	82	1240	9.7371
IE4-355M1-8	132	452	261	151	430	248	143	138	239	138	740	94.9	94.8	93.6	0.81	1704	1.6	2.0	7.7	90	1636	14.9330
IE4-355M2-8	160	540	312	180	513	296	171	165	285	165	740	95.1	95.0	93.8	0.82	2065	1.6	2.0	7.7	90	1875	17.6837
IE4-355L1-8	185	622	359	207	591	341	197	190	329	190	740	95.4	95.3	94.2	0.82	2388	1.6	2.0	7.8	90	1985	20.8276
IE4-355L2-8	200	672	388	224	639	369	213	206	356	206	740	95.4	95.3	94.2	0.82	2581	1.6	2.0	7.8	90	2090	22.3994

IE4-80-132

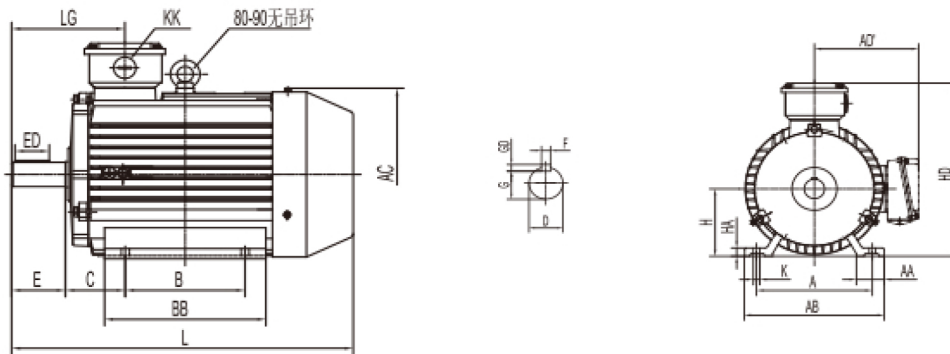

IE4-160-200

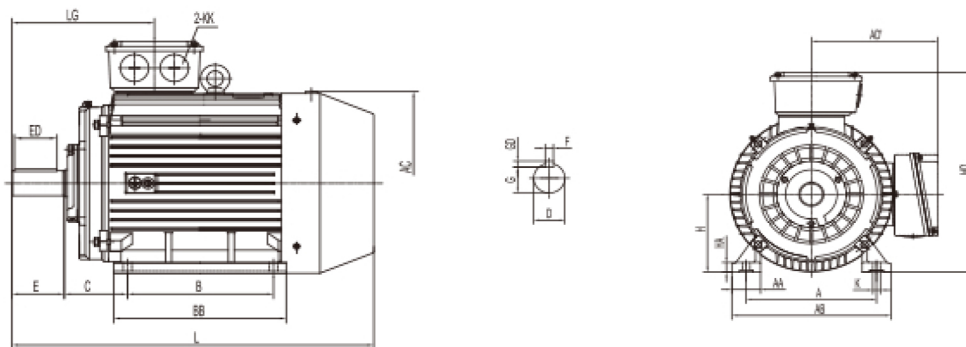

IE4-225-280

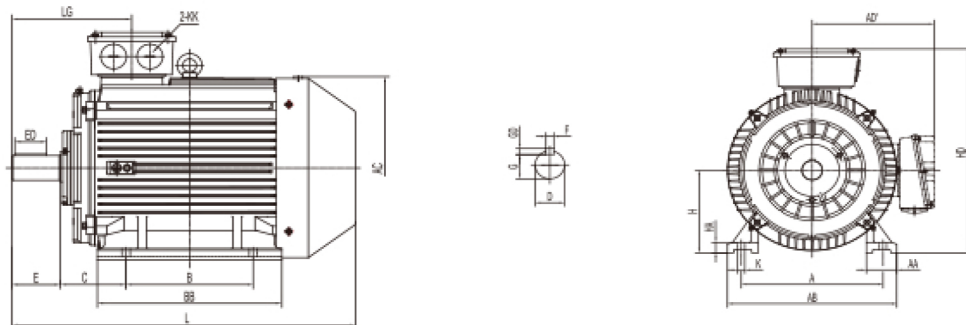

IE4-315-355

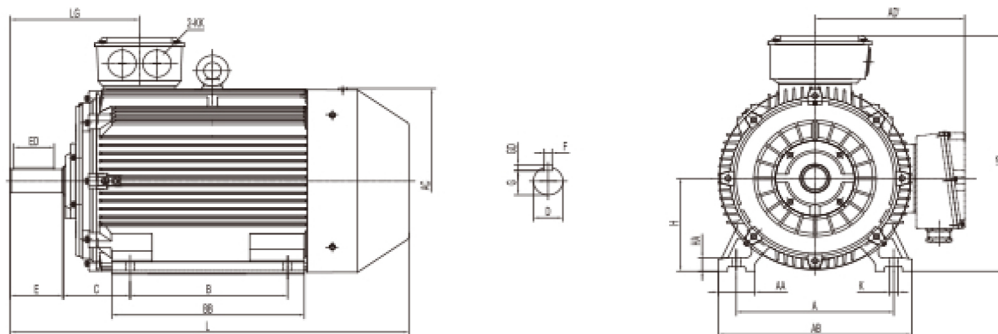

机座号	A	AA	AB	AC	AD'	B	BB	C	D	E	ED	F	G	GD	H	HA	HD	K	KK	L	LG
80	125	34	160	180	160	100	142	50	19	40	22	6	15.5	6	80	10	240	10	M25X1.5	305	112
90S	140	36	180	210	170	100	180	56	24	50	32	8	20	7	90	12.5	260	10	M25X1.5	340	132
90L	140	36	180	210	165	125	210	56	24	50	32	8	20	7	90	12.5	260	10	M25X1.5	365	132
100L	160	40	200	220	185	140	233	63	28	60	40	8	24	7	100	14	285	12	M25X1.5	403	153
112M	190	45	236	236	205	140	252	70	28	60	40	8	24	7	112	14	315	12	M32X1.5	410	144
132S	216	52	265	275	225	140	220	89	38	80	56	10	33	8	132	16	355	12	M32X1.5	485	167
132M	216	52	265	275	225	178	258	89	38	80	56	10	33	8	132	16	355	12	M32X1.5	525	167
160M	254	65	320	330	265	210	325	108	42	110	80	12	37	8	160	19	425	14.5	M40X1.5	665	267.5
160L	254	65	320	330	265	254	325	108	42	110	80	12	37	8	160	19	425	14.5	M40X1.5	665	267.5
180M	279	70	350	380	285	241	335	121	48	110	80	14	42.5	9	180	22	465	14.5	M40X1.5	730	277
180L	279	70	350	380	285	279	335	121	48	110	80	14	42.5	9	180	22	465	14.5	M40X1.5	730	277
200L	318	80	390	420	310	305	355	133	55	110	90	16	49	10	200	25	510	18.5	M50X1.5	790	298
225S(4-6P)	356	75	435	465	335	286	350	149	60	140	100	18	53	11	225	28	560	18.5	M50X1.5	840	338
225M(2P)	356	75	435	465	335	311	375	149	55	110	80	16	49	10	225	28	560	18.5	M50X1.5	865	338
225M(4-6P)	356	75	435	465	335	311	375	149	60	140	100	18	53	11	225	28	560	18.5	M50X1.5	865	338
250M(2P)	406	100	485	520	385	349	450	168	60	140	100	18	53	11	250	33	635	24	M63X1.5	945	360
250M(4-6P)	406	100	485	520	385	349	450	168	65	140	100	18	58	11	250	33	635	24	M63X1.5	945	360
280S(2P)	457	105	550	570	415	368	490	190	65	140	100	18	58	11	280	35	695	24	M63X1.5	990	344
280S(4-6P)	457	105	550	570	415	368	490	190	75	140	100	20	67.5	12	280	35	695	24	M63X1.5	990	344
280M(2P)	457	105	550	570	415	419	540	190	65	140	100	18	58	11	280	35	695	24	M63X1.5	1045	344
280M(4-6P)	457	105	550	570	415	419	540	190	75	140	100	20	67.5	12	280	35	695	24	M63X1.5	1045	344
315S(2P)	508	125	630	650	490	406	515	216	65	140	100	18	58	11	315	45	805	28	M63X1.5	1185	417
315M(2P)	508	125	630	650	490	457	625	216	65	140	100	18	58	11	315	45	805	28	M63X1.5	1295	417
315L(2P)	508	125	630	650	490	508	625	216	65	140	100	18	58	11	315	45	805	28	M63X1.5	1295	417
315S(4-6P)	508	125	630	650	490	406	515	216	80	170	130	22	71	14	315	45	805	28	M63X1.5	1215	417
315M(4-6P)	508	125	630	650	490	457	625	216	80	170	130	22	71	14	315	45	805	28	M63X1.5	1325	417
315L(4-6P)	508	125	630	650	490	508	625	216	80	170	130	22	71	14	315	45	805	28	M63X1.5	1325	417
355M(2P)	610	125	735	735	645	560	850	254	75	140	110	20	67.5	12	355	49	1000	28	M63X1.5	1620	420
355L1(2P)	610	125	735	735	645	630	850	254	75	140	110	20	67.5	12	355	49	1000	28	M63X1.5	1620	420
355L2,3(2P)	630	135	760	800	770	800	1140	224	80	170	130	22	71	14	355	52	1000	35	M63X1.5	1870	472
355M(4-6P)	610	125	735	735	645	560	850	254	95	170	140	25	86	14	355	49	1000	28	M63X1.5	1650	450
355L1(4-6P)	610	125	735	735	645	630	850	254	95	170	140	25	86	14	355	49	1000	28	M63X1.5	1650	450
355L3-4P/L2-6P	630	135	760	800	770	800	1140	224	110	210	180	28	100	16	355	52	1000	35	M63X1.5	1940	512

IE4-80-132

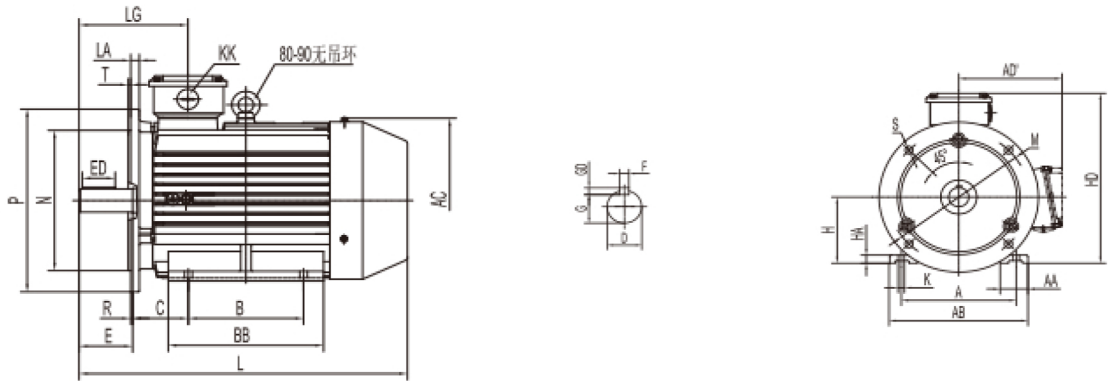

IE4-160-200

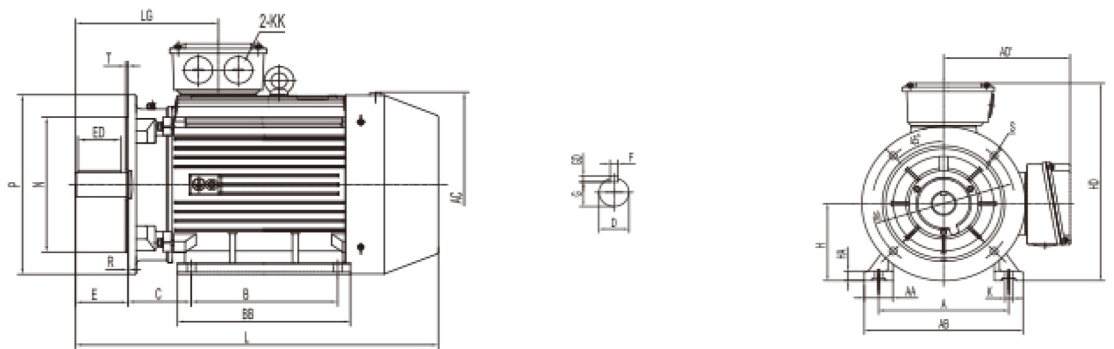

IE4-225-280

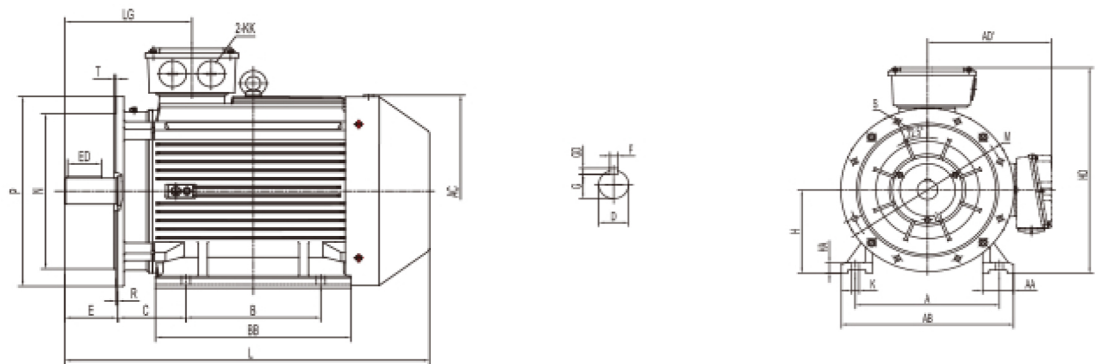

IE4-315-355

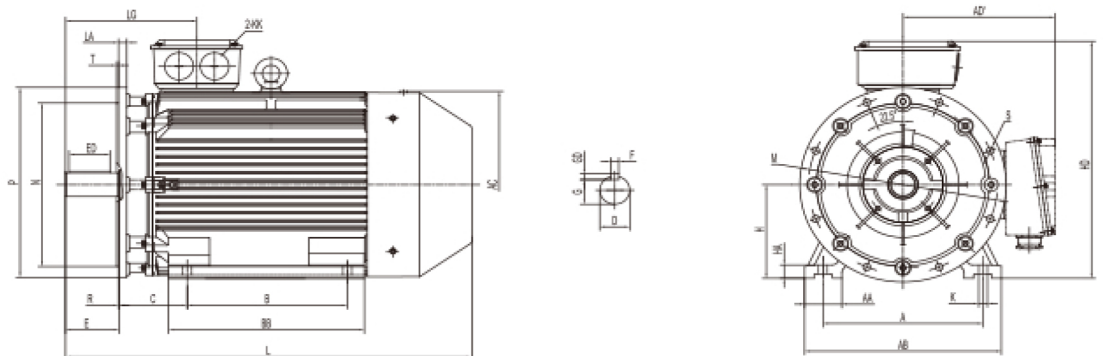

机座号	A	AA	AB	AC	AD'	B	BB	C	D	E	ED	F	G	GD	H	HA	HD	K	L	LA	LG	M	N	P	S	T	KK
80	125	34	160	180	160	100	142	50	19	40	22	6	15.5	6	80	10	240	10	305	14	112	165	130	200	12	3.5	M25X1.5
90S	140	36	180	210	170	100	180	56	24	50	32	8	20	7	90	13	260	10	340	12	132	165	130	200	12	3.5	M25X1.5
90L	140	36	180	210	165	125	210	56	24	50	32	8	20	7	90	13	260	10	365	12	132	165	130	200	12	3.5	M25X1.5
100L	160	40	200	220	185	140	233	63	28	60	40	8	24	7	100	14	285	12	403	14	153	215	180	250	14.5	4	M25X1.5
112M	190	45	230	236	205	140	252	70	28	60	40	8	24	7	112	14	315	12	410	12	144	215	180	250	14.5	4	M32X1.5
132S	216	52	265	275	225	140	220	89	38	80	56	10	33	8	132	16	355	12	485	13	167	265	230	300	14.5	4	M32X1.5
132M	216	52	265	275	225	178	258	89	38	80	56	10	33	8	132	16	355	12	525	13	167	265	230	300	14.5	4	M32X1.5
160M	254	65	320	330	265	210	325	108	42	110	80	12	37	8	160	19	425	14.5	665	15	268	300	250	350	18.5	5	M40X1.5
160L	254	65	320	330	265	254	325	108	42	110	80	12	37	8	160	19	425	14.5	665	15	268	300	250	350	18.5	5	M40X1.5
180M	279	70	350	380	285	241	335	121	48	110	80	14	42.5	9	180	22	465	14.5	730	15	277	300	250	350	18.5	5	M40X1.5
180L	279	70	350	380	285	279	335	121	48	110	80	14	42.5	9	180	22	465	14.5	730	15	277	300	250	350	18.5	5	M40X1.5
200L	318	80	390	420	310	305	355	133	55	110	90	16	49	10	200	25	510	18.5	790	17	298	350	300	400	18.5	5	M50X1.5
225S(4-6P)	356	75	435	465	335	286	350	149	60	140	100	18	53	11	225	28	560	18.5	840	19	338	400	350	450	18.5	5	M50X1.5
225M(2P)	356	75	435	465	335	311	375	149	55	110	80	16	49	10	225	28	560	18.5	865	19	338	400	350	450	18.5	5	M50X1.5
225M(4-6P)	356	75	435	465	335	311	375	149	60	140	100	18	53	11	225	28	560	18.5	865	19	338	400	350	450	18.5	5	M50X1.5
250M(2P)	406	100	485	520	385	349	450	168	60	140	100	18	53	11	250	33	635	24	945	20	360	500	450	550	18.5	5	M63X1.5
250M(4-6P)	406	100	485	520	385	349	450	168	65	140	100	18	58	11	250	33	635	24	945	20	360	500	450	550	18.5	5	M63X1.5
280S(2P)	457	105	550	570	415	368	490	190	65	140	100	18	58	11	280	35	695	24	990	22	344	500	450	550	18.5	5	M63X1.5
280S(4-6P)	457	105	550	570	415	368	490	190	75	140	100	20	67.5	12	280	35	695	24	990	22	344	500	450	550	18.5	5	M63X1.5
280M(2P)	457	105	550	570	415	419	540	190	65	140	100	18	58	11	280	35	695	24	1045	22	344	500	450	550	18.5	5	M63X1.5
280M(4-6P)	457	105	550	570	415	419	540	190	75	140	100	20	67.5	12	280	35	695	24	1045	22	344	500	450	550	18.5	5	M63X1.5
315S(2P)	508	125	630	650	490	406	515	216	65	140	100	18	58	11	315	45	805	28	1185	24	417	600	550	660	24	6	M63X1.5
315M(2P)	508	125	630	650	490	457	625	216	65	140	100	18	58	11	315	45	805	28	1295	24	417	600	550	660	24	6	M63X1.5
315L(2P)	508	125	630	650	490	508	625	216	65	140	100	18	58	11	315	45	805	28	1295	24	417	600	550	660	24	6	M63X1.5
315S(4-6P)	508	125	630	650	490	406	515	216	80	170	130	22	71	14	315	45	805	28	1185	24	417	600	550	660	24	6	M63X1.5
315M(4-6P)	508	125	630	650	490	457	625	216	80	170	130	22	71	14	315	45	805	28	1325	24	417	600	550	660	24	6	M63X1.5
315L(4-6P)	508	125	630	650	490	508	625	216	80	170	130	22	71	14	315	45	805	28	1325	24	417	600	550	660	24	6	M63X1.5
355M(2P)	610	125	735	735	645	560	850	254	75	140	110	20	67.5	12	355	49	1000	28	1620	25	420	740	680	800	24	6	M63X1.5
355L1(2P)	610	125	735	735	645	630	850	254	75	140	110	20	67.5	12	355	49	1000	28	1620	25	420	740	680	800	24	6	M63X1.5
355L2,3(2P)	630	135	760	800	770	800	1140	224	80	170	130	22	71	14	355	52	1000	35	1870	25	472	840	780	900	24	6	M63X1.5
355M(4-6P)	610	125	735	735	645	560	850	254	95	170	140	25	86	14	355	49	1000	28	1650	25	450	740	680	800	24	6	M63X1.5
355L1(4-6P)	610	125	735	735	645	630	850	254	95	170	140	25	86	14	355	49	1000	28	1650	25	450	740	680	800	24	6	M63X1.5
355L3-4PL2-6P	630	135	760	800	770	800	1140	224	110	210	180	28	100	16	355	52	1000	35	1940	25	512	840	780	900	24	6	M63X1.5

Note: R=0

IE4-80-132

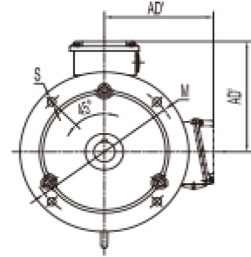
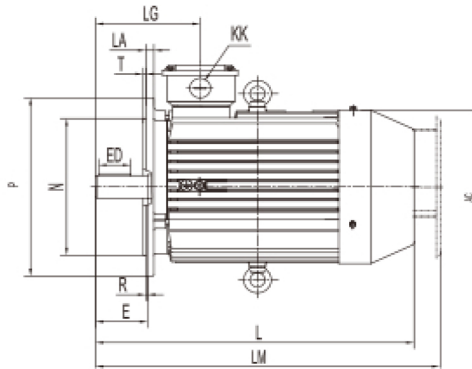

IE4-160-200

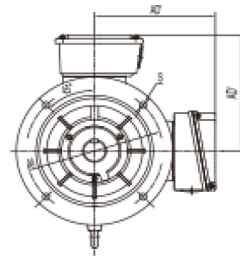
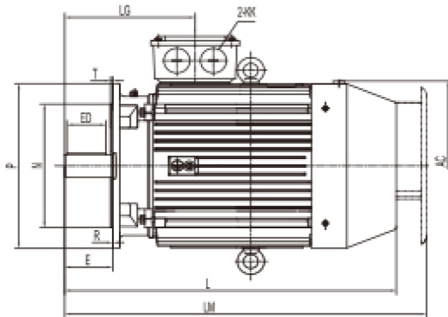

IE4-225-280

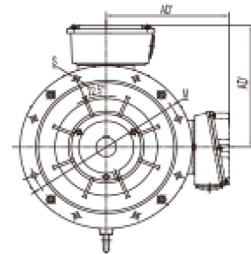
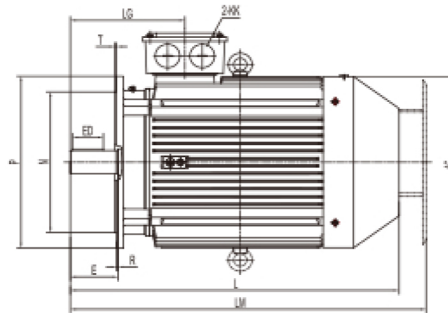

IE4-315-355

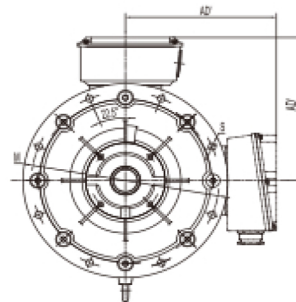
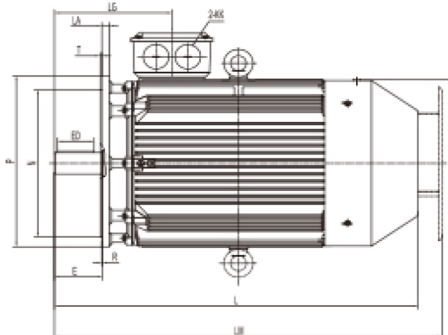

机座号	AC	AD'	D	E	ED	F	G	GD	L	LA	LG	LM	M	N	P	S	T	KK
80	175	160	19	40	22	6	15.5	6	305	14	112	345	165	130	200	12	3.5	M25X1.5
90S	195	170	24	50	32	8	20	7	340	12	132	380	165	130	200	12	3.5	M25X1.5
90L	195	170	24	50	32	8	20	7	365	12	132	405	165	130	200	12	3.5	M25X1.5
100L	215	185	28	60	40	8	24	7	403	14	153	450	215	180	250	14.5	4	M25X1.5
112M	240	205	28	60	40	8	24	7	410	12	144	460	215	180	250	14.5	4	M32X1.5
132S	275	225	38	80	56	10	33	8	485	13	167	535	265	230	300	14.5	4	M32X1.5
132M	275	225	38	80	56	10	33	8	525	13	167	575	265	230	300	14.5	4	M32X1.5
160M	330	265	42	110	80	12	37	8	665	15	268	720	300	250	350	18.5	5	M40X1.5
160L	330	265	42	110	80	12	37	8	665	15	268	720	300	250	350	18.5	5	M40X1.5
180M	380	285	48	110	80	14	42.5	9	730	15	277	785	300	250	350	18.5	5	M40X1.5
180L	380	285	48	110	80	14	42.5	9	730	15	277	785	300	250	350	18.5	5	M40X1.5
200L	420	310	55	110	90	16	49	10	790	17	298	860	350	300	400	18.5	5	M50X1.5
225S(4-6P)	465	335	60	140	100	18	53	11	840	19	338	910	400	350	450	18.5	5	M50X1.5
225M(2P)	465	335	55	110	80	16	49	10	865	19	338	935	400	350	450	18.5	5	M50X1.5
225M(4-6P)	465	335	60	140	100	18	53	11	865	19	338	935	400	350	450	18.5	5	M50X1.5
250M(2P)	520	385	60	140	100	18	53	11	945	20	360	1025	500	450	550	18.5	5	M63X1.5
250M(4-6P)	520	385	65	140	100	18	58	11	945	20	360	1025	500	450	550	18.5	5	M63X1.5
280S(2P)	570	415	65	140	100	18	58	11	990	22	344	1080	500	450	550	18.5	5	M63X1.5
280S(4-6P)	570	415	75	140	100	20	67.5	12	990	22	344	1080	500	450	550	18.5	5	M63X1.5
280M(2P)	570	415	65	140	100	18	58	11	1045	22	344	1080	500	450	550	18.5	5	M63X1.5
280M(4-6P)	570	415	75	140	100	20	67.5	12	1045	22	344	1080	500	450	550	18.5	5	M63X1.5
315S(2P)	650	490	65	140	100	18	58	11	1185	24	417	1285	600	550	660	24	6	M63X1.5
315M(2P)	650	490	65	140	100	18	58	11	1295	24	417	1395	600	550	660	24	6	M63X1.5
315L(2P)	650	490	65	140	100	18	58	11	1295	24	417	1395	600	550	660	24	6	M63X1.5
315S(4-6P)	650	490	80	170	130	22	71	14	1215	24	417	1315	600	550	660	24	6	M63X1.5
315M(4-6P)	650	490	80	170	130	22	71	14	1325	24	417	1425	600	550	660	24	6	M63X1.5
315L(4-6P)	650	490	80	170	130	22	71	14	1325	24	417	1425	600	550	660	24	6	M63X1.5
355M(2P)V1	735	645	75	140	110	20	67.5	12	1620	25	420	1720	740	680	800	24	6	M63X1.5
355L1(2P)V1	735	645	75	140	110	20	67.5	12	1620	25	420	1720	740	680	800	24	6	M63X1.5
355L2,3(2P)V1	800	770	80	170	130	22	71	14	1870	25	472	1970	840	780	900	24	6	M63X1.5
355M(4-6P)V1	735	645	95	170	140	25	86	14	1650	25	450	1750	740	680	800	24	6	M63X1.5
355L1(4-6P)V1	735	645	95	170	140	25	86	14	1650	25	450	1750	740	680	800	24	6	M63X1.5
355L3-4PL2-6PV1	800	770	110	210	180	28	100	16	1940	25	512	2040	840	780	900	24	6	M63X1.5

Note: R=0

IE4-80-160 B14A

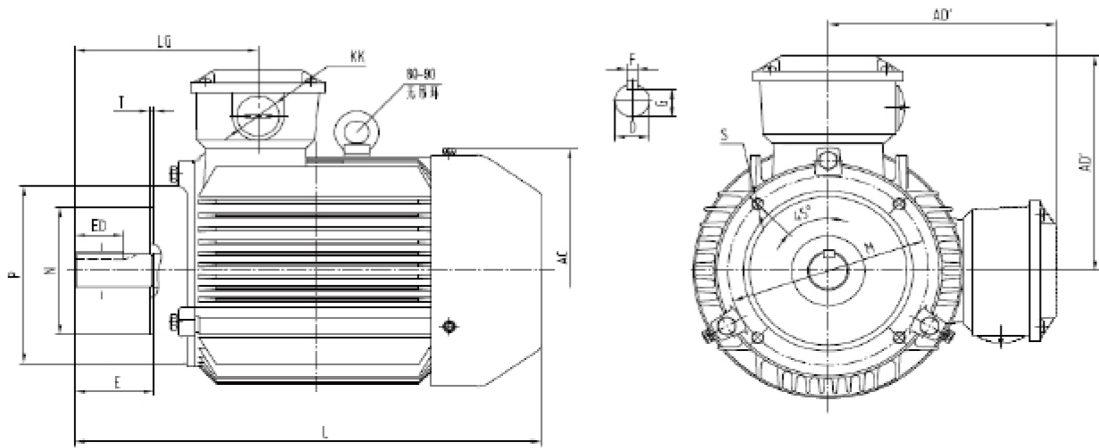

IE4-80-160-132 B14B

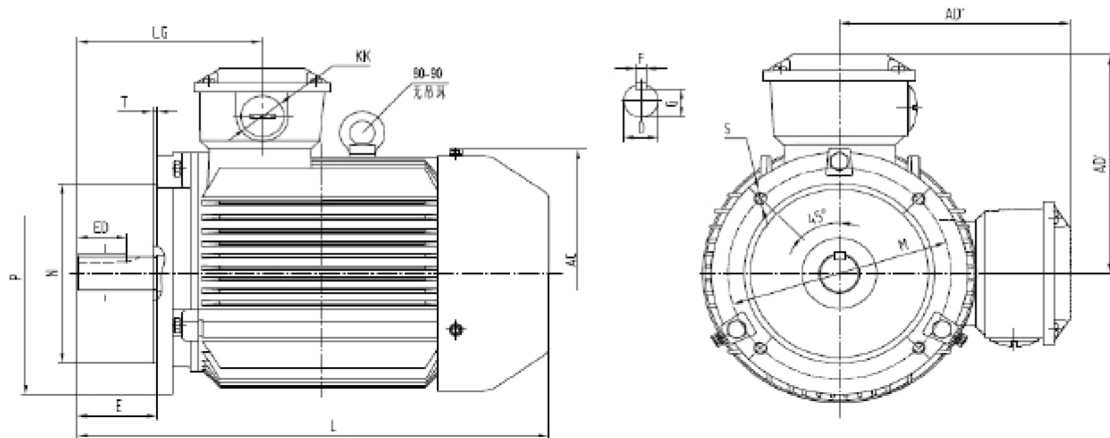

FRAME SIZE	AC	AD'	D	E	ED	F	G	GD	KK	L	LG	B14A					B14B				
												M	N	P	S	T	M	N	P	S	T
80M	175	155	19	40	22	6	15.5	6	M25X1.5	305	112	100	80	120	M6	3	130	110	160	M8	3.5
90S	195	175	24	50	32	8	20	7	M25X1.5	360	132	115	95	140	M8	3	130	110	160	M8	3.5
90L	195	175	24	50	32	8	20	7	M25X1.5	390	132	115	95	140	M8	3	130	110	160	M8	3.5
100L	215	180	28	60	40	8	24	7	M25X1.5	435	153	130	110	160	M8	3.5	165	130	200	M10	3.5
112M	240	190	28	60	40	8	24	7	2XM32X1.5	470	144	130	110	160	M8	3.5	165	130	200	M10	3.5
132S	275	210	38	80	56	10	33	8	2XM32X1.5	510	167	165	130	200	M10	3.5	215	180	250	M12	4
132M	275	210	38	80	56	10	33	8	2XM32X1.5	560	167	165	130	200	M10	3.5	215	180	250	M12	4
160M	330	255	42	110	80	12	37	8	2XM40X1.5	700	268	215	180	250	M12	4	-	-	-	-	-
160L	330	255	42	110	80	12	37	8	2XM40X1.5	700	268	215	180	250	M12	4	-	-	-	-	-